

### Taraud



1 M8  
2 M12  
3 M16

1 KAT 210208  
2 KAT 210212  
3 KAT 210216

### Taraudage métrique

#### Spécifications des tarauds et forets

FILETS	TARAUDS	FORETS
<b>M8</b>	<b>M8</b>	<b>6,8 mm</b>
<b>M12</b>	<b>M12</b>	<b>10,2 mm</b>
<b>M16</b>	<b>M16</b>	<b>14,0 mm</b>

Pour le filetage des embouts de profilé en prévision de l'installation des vis KAT100803 et KAT 101200 filet standard, nous vous recommandons l'utilisation des tarauds du type "roulé" (forming tap).

### Gabarit de perçage

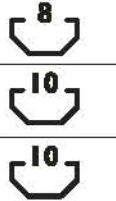

1 ø 7,4  
2 ø 9,5  
3 ø 22



### Gabarit de perçage



45 x 90

1 ø 9,5



### Douille métrique



1 Douille 3/8 13<sub>MM</sub>  
réf KAT100820

1 KAT 210074

2 KAT 210095

3 KAT 210022

1 KAT 210096

KAT 210663